

**THE UNITED REPUBLIC OF TANZANIA
NATIONAL EXAMINATIONS COUNCIL OF TANZANIA
CERTIFICATE OF SECONDARY EDUCATION EXAMINATION**

031/1

PHYSICS 1
(For Both School and Private Candidates)

Time: 3 Hours

Year: 2022

Instructions

1. This paper consists of sections A, B and C with a total of **eleven (11)** questions.
2. Answer **all** questions in sections A and B and **two (2)** questions from section C.
3. Section A carries **fifteen (15)** marks, section B **sixty (60)** marks and section C carries **twenty five (25)** marks.
4. Cellular phones and any unauthorized materials are **not** allowed in the examination room.
5. Non-programmable calculators and mathematical tables may be used.
6. Write your **Examination Number** on every page of your answer booklet(s).
7. Where necessary the following constants may be used:
 - (i) Acceleration due to gravity, $g = 10 \text{ m/s}^2$.
 - (ii) Density of water = 1.0 g/cm^3 .
 - (iii) Pie, $\pi = 3.14$.
 - (iv) Speed of sound is 340 m/s .



SECTION A (15 Marks)

Answer **all** questions in this section.

1. For each of the items (i) - (x), choose the correct answer from among the given alternatives and write its letter beside the item number in the answer booklet provided. **(10 marks)**
- (i) Which set best represents fundamental quantities with their SI units?
- A Length (km), mass (kg), time (s), temperature ($^{\circ}$ C), amount of substance (mol) and electric current (A).
 - B Length (m), mass (kg), force (N), temperature (K), time (s), amount of substance (mol) and energy (J).
 - C Length (m), mass (kg), time (s), electric current (I), temperature ($^{\circ}$ C) and amount of substance (mol).
 - D Length (m), mass (kg), time (s), temperature (K), electric current (A) and luminous intensity (Cd).
 - E Length (km), mass (g), time (s), temperature (K), electric current (A) and amount of substance (mol).
- (ii) Which one of the following conditions must be satisfied for a body to float?
- A Apparent weight is equal to the difference between real weight of the body and its upthrust.
 - B Upthrust equals to the weight of the fluid displaced.
 - C Real weight of the body equals to its upthrust.
 - D Apparent weight is equal to the product of real weight of a body and its upthrust.
 - E Density of a body is equal to the density of surrounding fluid.
- (iii) Which statement about the properties of gaseous state of matter is true?
- A Particles vibrate in fixed positions.
 - B The shape is indefinite with definite volume.
 - C Particles are closely packed together.
 - D Both shape and volume are definite.
 - E The inter-particle distance is large.
- (iv) At which position will the object be placed for a concave mirror to form virtual, magnified and erect image behind the mirror?
- A Between the principle focus (F) and the pole (P) in front of the mirror.
 - B Between the principle focus (F) and the pole (P) behind the mirror.
 - C Between the centre of curvature (C) and principle focus (F) in front of the mirror.
 - D Between the centre of curvature (C) and principle focus (F) behind the mirror.
 - E Between the centre of curvature (C) and the pole (P) in front of the mirror.

(v) Which of the following uniform motion graphs represents velocity?

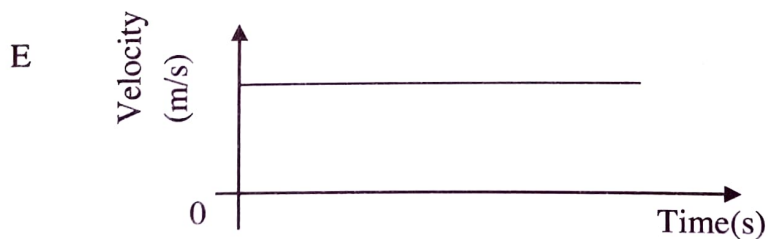
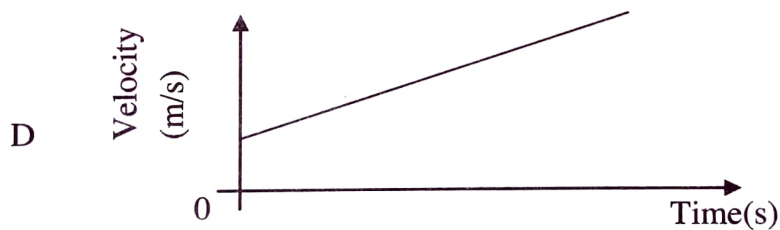
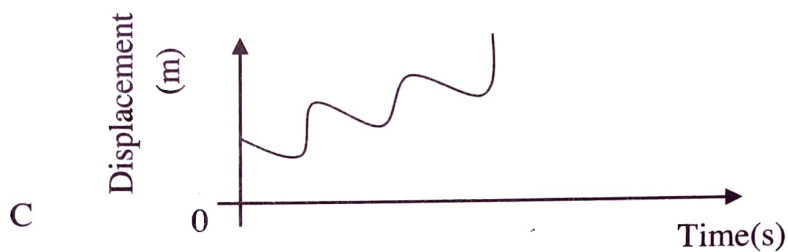
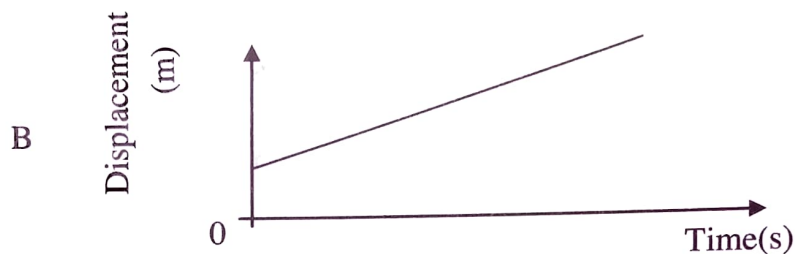
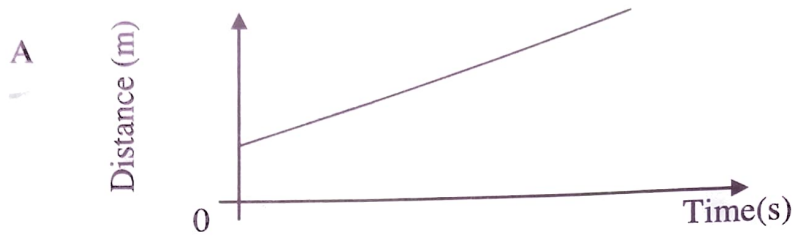

(vi) Two objects X and Y were supplied by equal quantities of thermal energy. It was observed that the temperature increase of object X is greater than the temperature increase of object Y. Which of the following statements explains the observation?

- A X has a lower melting point than Y.
- B X has a lower density than Y.
- C X has a lower thermal capacity than Y.
- D X is a better thermal conductor than Y.
- E X is heavier than Y.

- (vii) A hot water in a cup undergoes evaporation in an open air. What happens to the mass and weight of the water in the cup?
- A Both mass and weight decrease
 - B Mass decreases while weight stays the same
 - C Both mass and weight stay the same
 - D Mass increases while weight decreases
 - E Mass stays the same while weight decreases

- (viii) A student wishes to check the upper fixed point and the lower fixed point on Celsius scale thermometer as shown in Figure 1.

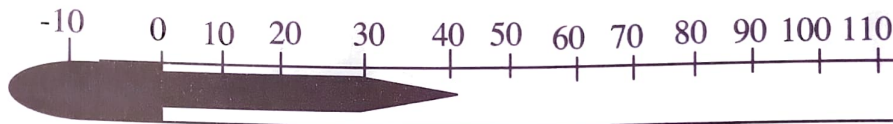

Figure 1

The student has four beakers namely *P*, *Q*, *R* and *S*.

P contains a mixture of ice and salt;

Q contains a mixture of ice and water;

R contains a mixture of boiling salt solution; and

S contains boiling water.

Which beakers should a student use to check the fixed points?

- A *P* and *R*
- B *P* and *S*
- C *Q* and *S*
- D *Q* and *R*
- E *S* and *R*

- (ix) Which one of the following is **not** a property of cathode rays?

- A They are a stream of fast moving protons.
- B They travel in straight lines.
- C They are deflected by electric fields.
- D They are deflected by magnetic fields.
- E They produce x-rays when stopped suddenly.

- (x) What does the term milky way mean?

- A A vast collection of asteroids.
- B One of the galaxies of the universe.
- C A group of stars that form a pattern in the sky.
- D One of the meteoroids.
- E One of the solar systems.

2. Match the applications of parts of the electromagnetic spectrum in **List A** with the corresponding parts of electromagnetic spectrum in **List B** by writing the letter of the correct response beside the item number in the answer booklet provided. (5 marks)

List A	List B
(i) Can be used to sterilize fruits and vegetables.	A Visible light
(ii) Stimulates the production of vitamin D in the human skin. <i>H</i>	B X-rays
(iii) Stimulates the sensitive cells in the retina. <i>A</i>	C Microwaves
(iv) Emitted by a remote control. <i>F</i>	D Alpha particles
(v) Used for rapid cooking in an oven. <i>C</i>	E Gamma rays
	F Infra-red rays
	G Radio waves
	H Ultra-violet rays

SECTION B (60 Marks)

Answer **all** questions in this section.

3. (a) A concave mirror is used to form an image of a pin object. By using a well labelled diagram; show how you can obtain an upright and enlarged image. (4 marks)
- (b) With the aid of diagrams, describe three ways in which a human eye can be compared to photographic camera. (6 marks)
4. (a) Carefully study the Figure 2 and then answer the question that follows:

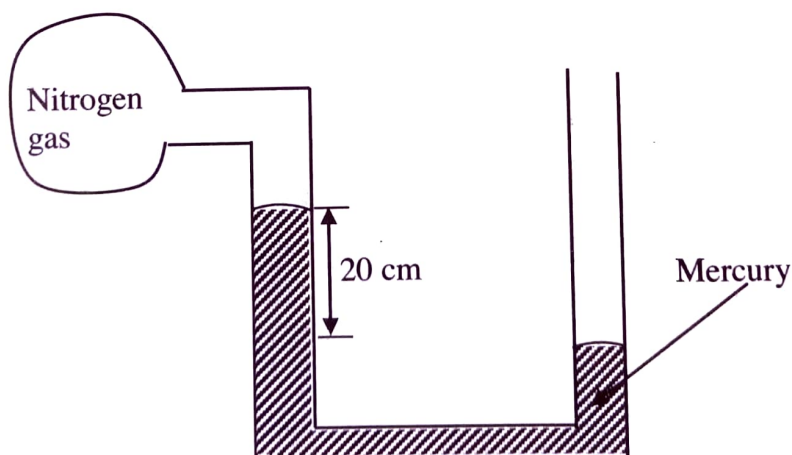

Figure 2

Determine the pressure of the gas given that atmospheric pressure is 102,000 Pa and density of mercury is 13.6 g/cm^3 . (5 marks)

(b) Why a ship cannot overturn when hit by a strong wave on one side? (5 marks)

wave transfers energy, but not medium

5. (a) Figure 3 shows a car moving to a farm. Identify four pairs of action/reaction forces taking place and describe their effects. (4 marks)

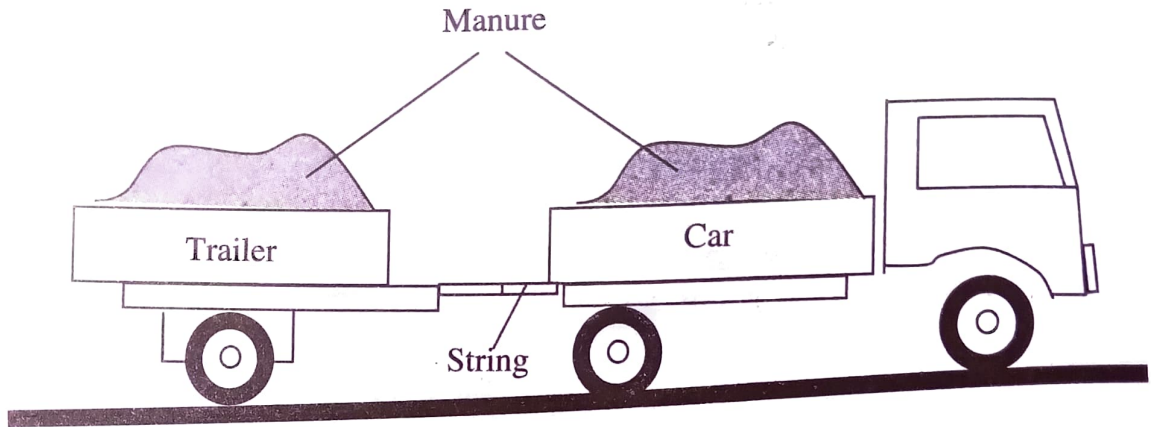
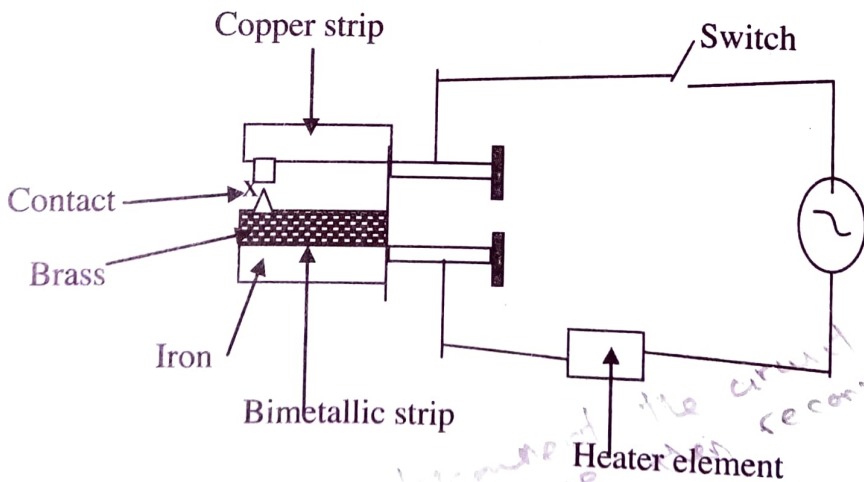

Figure 3

(b) A pulley system with efficiency of 75% is made up of four pulleys. Sketch a well labelled diagram of this machine and then determine the effort required to raise two bags of maize each weighing 100 kg. (6 marks)

6. (a) Figure 4 shows a circuit diagram for controlling the temperature of a sitting room. Describe how the circuit controls the temperature when the switch is closed. (6 marks)



The B.S. disconnects the circuit when the heater element gets too hot and reconnects after it cools down.

Figure 4

- (b) Why does it take less time to boil vegetables in a cooking pot with a lid on than one without a lid? Briefly explain. (4 marks)
7. (a) An electric kettle containing two heating coils A and B is used to boil water. If it takes 10 minutes for coil A to boil water and 20 minutes for coil B to boil the same amount of water, how long does it take for the water to boil when the two coils are joined in series? (6 marks)
- (b) The half-life of a radioactive substance is 138 days. A sample of the substance has 1.6×10^{11} undecayed atoms at the beginning. How many undecayed atoms will be left after 690 days? (4 marks)
8. (a) Analyze five effects of volcanoes eruption on the Earth's surface. (5 marks)
Death - Soil formation - Earthquake - Loss of biodiversity - Trust attraction - Global warming
- (b) A tuning fork produces resonances in a tube at 40 cm and 85 cm respectively. Calculate the wavelength of the tuning fork. (5 marks)

SECTION C (25 Marks)

Answer two (2) questions from this section.

9. (a) A stretched taut string of length 40 cm and mass 2×10^{-3} kg is pulled with a tension of 100 N. Determine the frequency of the first and second harmonics when it is plucked at its middle. (6 marks)
- (b) When a potential difference of 60 V is applied across a primary circuit of a transformer, a current of 3.7 A flows. Find the potential difference across the secondary circuit if there is a current of 0.15 A flowing in it. Take the efficiency of the transformer to be 95 %. (6.5 marks)
10. (a) Explain four factors that affect the resistance of a conductor. (4 marks)
- (b) The parallel combination of 2Ω and 5Ω resistors are connected across the external resistor of 3Ω through the supply of 4 V. Draw the circuit diagram and find the current flowing through a 5Ω resistor. (5 marks)
- (c) With the aid of a common-emitter amplifier circuit, explain why n-p-n transistor is named so. (3.5 marks)
11. (a) How does sound from the disco hall transmitted into your room? Briefly explain. (6 marks)
people are not as absorber of sound
- (b) How are the microwaves used in cooking? (2.5 marks)
sound will be maintain
- (c) How is the destructive interference used in noise reduction system? Briefly describe. (4 marks)